



EENA Operations Document

112 service chain description

Title: 112 service chain definition
Version: 1.0
Code: 1_1_1_ServChain_v1.0.doc
Revision Date: 10-06-2011

Status of the document: Draft For comments **Approved**



ABSTRACT

A call to the emergency services through the 112 number by citizens in distress and the arrival of help at the location of the incident corresponds to a complex series of events which is analysed in the present document. To get help, the citizen in distress should first know which number to call and should have at his/her disposal a functioning telecommunication device. To get in contact with the 112 call taker the citizen should also have access to a network. After initialising the 112 call the caller should reach as soon as possible an available call taker, who will collect data about the nature of the incident, its location and, in some countries, the identity of the caller. Following that, the decision is taken to dispatch the appropriate resources as necessary.

The present document describes the models which apply to the organisation of the 112 emergency calls' handling. Although this organisation varies from country to country, in general, it covers specific tasks i.e. the reception of the call, the data collection (i.e. caller location, detailed data about the emergency situation and, if possible, call history data), the classification of the call and finally the dispatch of appropriate intervention resources. These tasks may be executed in several steps and by different organisations. The main differences correspond to the number of organisations involved in the emergency calls handling chain, the types of organisations in charge of first reception of 112 emergency calls and the tasks they fulfil and, finally, the division of the tasks in several steps. The different models of organisation are presented schematically and explained in detail.

An informative annex contains descriptions of the organisations dealing with calls to the 112 emergency number (not of organisations dealing with other national emergency numbers) on the basis of contributions submitted by EENA's members. As the corresponding organisations in several countries are in the process of being restructured this document should be considered as valid for the date of its publication.



Table of contents

1	Introduction.....	4
2	Definitions	4
3	112 Service Chain	4
4	112 Emergency calls handling chain.....	6
5	Models	7
5.1	ERO independent PSAP handling 112 calls	7
5.1.1	Call-Taking and dispatching.....	7
5.1.2	Filtering stage 1 PSAP and resource dispatching stage 2 PSAPs.....	8
5.1.3	Data gathering and parallel dispatch by stage 1 PSAP, resource dispatching by stage 2	9
5.1.4	Data gathering and parallel dispatch by stage 1 PSAP, resource dispatching by stage 2 in an integrated control room.....	10
5.2	Emergency response organisation handling 112 calls	11
	ANNEX Organisation in different countries	13
	Andorra.....	13
	Austria	13
	Belgium.....	13
	Bulgaria	14
	Cyprus	14
	Croatia.....	14
	Czech Republic.....	14
	Denmark	15
	Estonia.....	15
	Finland.....	15
	France.....	15
	Germany	16
	Greece	16
	Hungary	16
	Ireland	16
	Italy	17
	Latvia	17
	Lithuania	17
	Luxembourg	17
	Malta	18
	Netherlands	18
	Norway	18
	Poland.....	18
	Portugal	19
	Romania.....	19
	Serbia	19
	Slovakia	19
	Slovenia	20
	Spain	20
	Sweden	20
	Turkey	21
	United Kingdom.....	21



1 Introduction

In an emergency situation, the citizen has to know the number to contact emergency services, and thus, be able to ask for help. The knowledge of such number is the first link of the emergency service chain. After this emergency number is dialled, emergency services have to answer the call appropriately following different steps: reception of the call, data collection, classification of the type of incident and, if needed, dispatch of the appropriate intervention resources.

The European emergency number 112 is available in all the Member States of the European Union and also in other European countries. There are countries where only this single emergency number is available and others that have different national, regional or local numbers for contacting fire and rescues services, police and emergency medical services. This document deals exclusively with how 112 emergency calls are handled in each country. It is worth to mention that the intention of this document is not to give a detailed description of operational protocols but a general overview of the main stages of the handling of emergency calls to the 112 number and the organisation in different countries.

This document was established with the collaboration of all members of the EENA Operations Committee.

2 Definitions

- Emergency Response Organisation (ERO): one of the following the police, fire and rescue, emergency medical services, coast guard, etc.
- Public Safety Answering Point (PSAP): organisation under the responsibility of a public authority or a private organisation under public mandate in charge of first reception of emergency calls.
- General emergency number: e.g. 112
- ERO independent PSAP: organisation in charge of handling all types of emergency calls. Its responsibilities and tasks may differ from one country to another.

3 112 Service Chain

A call to emergency services starts a sequence of tasks by different stakeholders taking part in the emergency service chain. However, this sequence will not be initiated if the person involved in the emergency situation is not aware of the emergency number to dial. This is the reason why every single step in the 112 chain is crucial.

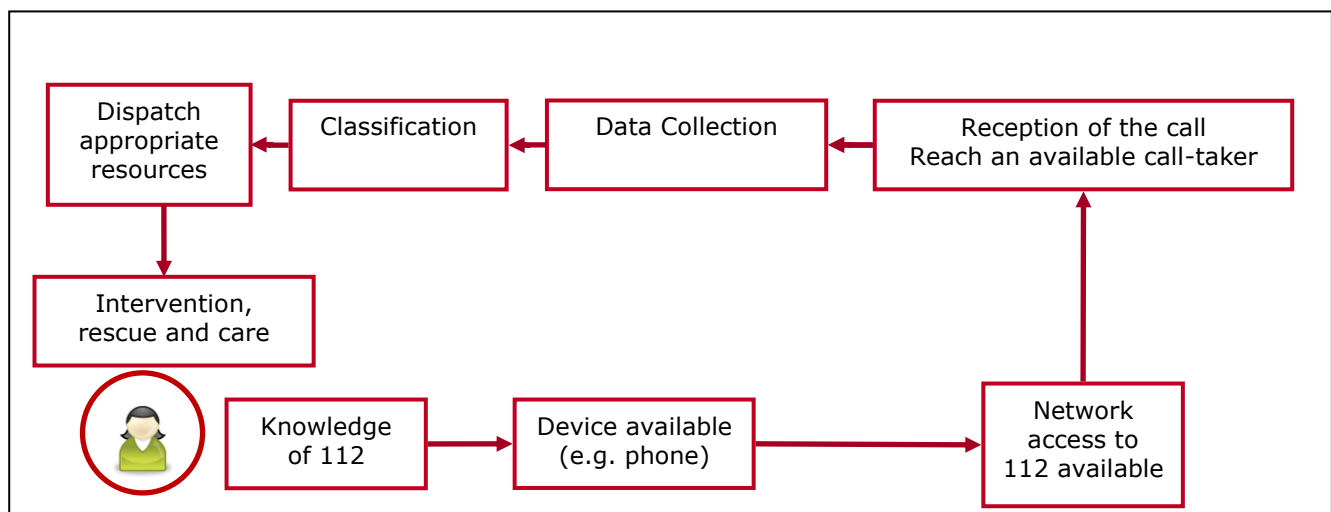



Knowledge of 112

In an emergency situation, the citizen may not be in a position to search and establish the appropriate emergency number to call. This number should be previously known so it can be dialled immediately in case of need. This is the reason why education of citizens and dissemination of information about the European emergency number is crucial.

The knowledge of the 112 emergency number is not as wide as desirable. The results of the European Emergency Number 112 Eurobarometer survey [Ref ¹] speak for themselves: only 50% of the citizens would call 112 in the event of emergencies in their own country and 76% would not use 112 in case of an emergency in another EU country.

The European dimension of 112 should be communicated to all citizens. It is important that travellers are informed about the availability of the European emergency number. Most people travelling abroad do not even think about the possibility of being involved in an emergency situation during their journey. This is why authorities cannot count into travellers' own initiative to find out what number to use in case of emergency. Campaigns and dissemination efforts are needed to ensure that travellers know what emergency number to use in case of distress.

Device

The first link of the chain is to know the emergency number. Then, the citizen needs a fully functioning device (e.g. mobile phone, public phone, etc.) which makes possible the contact with the emergency services. From mobile phones, it is possible to dial the emergency number even if the device is blocked. This way, the person in an emergency situation can use the device even if its functioning is unknown to him or her.

Network access to 112

Nowadays, emergency services usually accept to be contacted only through phone calls. This is the reason why the availability of mobile telephony within range plays an essential role. In some locations only one mobile network operator may be available. In these cases national roaming, i.e. when emergency calls are handled by another mobile network operator, will ensure that the citizen is able to contact emergency services.

Reach an available call-taker

Once the citizen has dialled 112 through an accessible network, emergency services have to ensure that he or she reaches an available call taker as soon as possible. Resources have to be optimised to guarantee a minimum waiting time.

Data collection

The first task to be achieved by emergency services is data collection. Where is the caller and what is happening are the most important pieces of information. These data are decisive in order to establish what resources are needed.

It is worth to mention that it is necessary to be able to establish a permanent link to the caller. To achieve this, it is crucial that PSAPs receive caller line identification, something that ensures that calling back is possible.

Dispatch appropriate resources

The appropriate resources have to be mobilised depending on where and what is happening. This information has to arrive to the appropriate resources.

Intervention

Once the resources have been dispatched, they have to arrive to the location of the incident and assist the citizens who are involved.

¹ http://ec.europa.eu/information_society/activities/112/docs/survey_summary2011.pdf
http://ec.europa.eu/information_society/activities/112/docs/report_2011.pdf

4 112 Emergency calls handling chain

The organisation of 112 emergency calls handling varies from one country to another but the aim and general tasks are the same. In this section the whole 112 emergency calls handling chain is described. This does not mean that all 112 calls end with the intervention of emergency services in place. Some 112 calls do not need the intervention of emergency services.

The general responsibilities of the emergency services are to ensure:

1. Reception of the call
2. Data Collection:
 - Reception of the caller location data
 - Collection of detailed data about the emergency situation
 - Call history data (if possible)
3. Classification of the call
4. Dispatch appropriate intervention resources

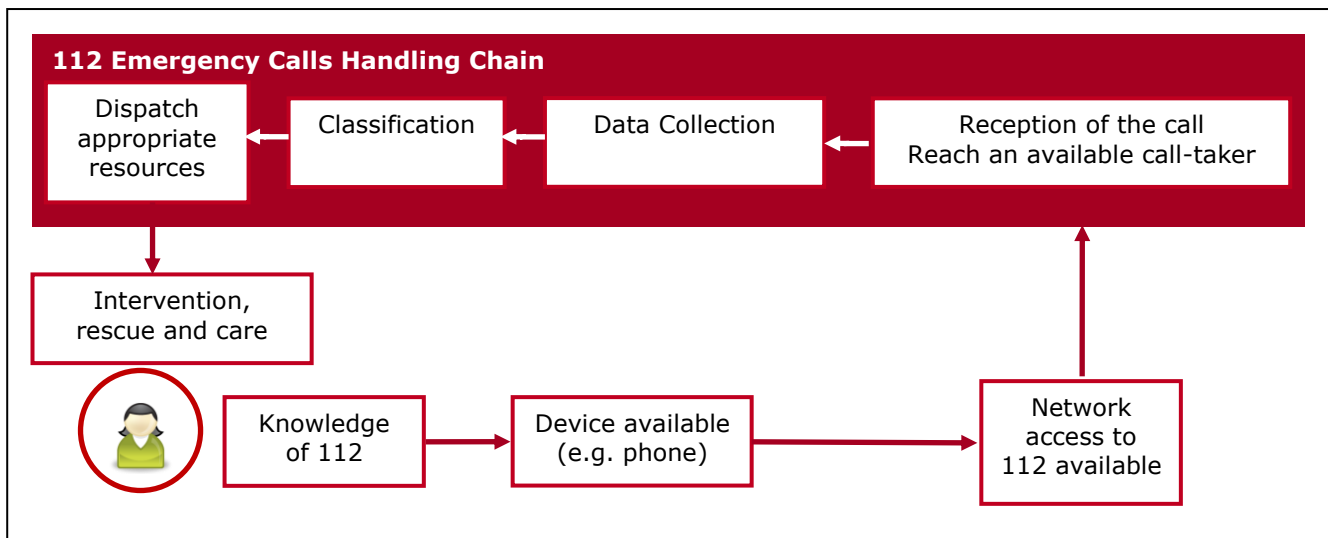

The organisation responsible for each task differs from one country to another. It is also worth to mention that tasks may be fulfilled in several steps and by several organisations. The main differences are:

- Number of organisations involved in the emergency calls handling chain: e.g., only one organisation fulfilling all tasks from call reception to the dispatch of intervention resources; many organisations, one for the reception of the call and data gathering and several EROs for the intervention resources dispatch, etc.
- Type of organisation in charge of first reception of 112 emergency calls: e.g., ERO independent PSAP, emergency response organisation PSAP, etc.
- Tasks fulfilled by the organisation in charge of the first reception of 112 emergency calls: e.g. organisation responsible for filtering the calls, organisation in charge of the whole chain tasks, etc.
- Division of the tasks in several steps: e.g. one organisation is in charge of calls' reception, data collection, and classification and other organisations are responsible for the final dispatch of intervention resources.

5 Models

5.1 ERO independent PSAP handling 112 calls

5.1.1 Call-Taking and dispatching

General description



The 112 calls are handled by civilian operators. The operators are highly trained and handle both 112 call-taking and intervention resources dispatch. In some cases police, fire and rescue and medical specialists are available to support the call takers.

112 calls handling chain in this model

The same PSAP is in charge of all tasks: classification of calls, data collection and dispatching the intervention resources to the incident.

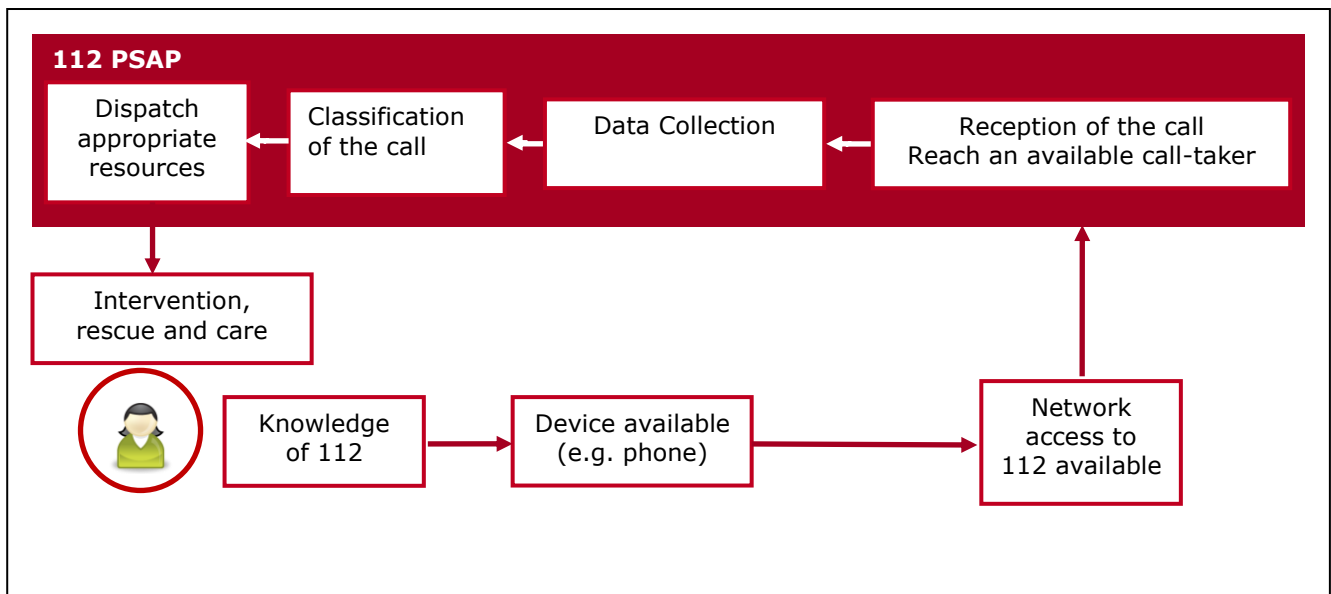

e.g. Finland

5.1.2 Filtering stage 1 PSAP and resource dispatching stage 2 PSAPs

General description

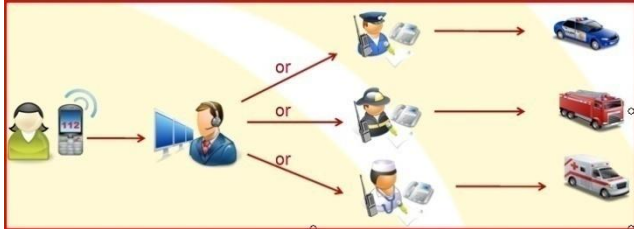

It is a two level organisation: there is an independent organisation in charge of first reception of the call and then the call is forwarded to the most appropriate local emergency response organisation.

112 calls handling chain in this model

The 112 calls handled by an ERO independent PSAP:

1. 112 calls handled by civilian operators
2. Stage 1 PSAP: Filtering tasks. The detailed gathering of data is not done by the stage 1 operator. The operator asks the caller with which emergency service he/she wants to get in contact (e.g. "What do you need? police, ambulance, fire and rescue services?").
3. Dispatch to medical / fire and rescue / police services: stage 1 PSAP forwards the call to the appropriate local emergency service
4. Detailed data gathering is done by the emergency response organisation operator
5. Dispatch of the intervention resources is ensured by the emergency response organisation

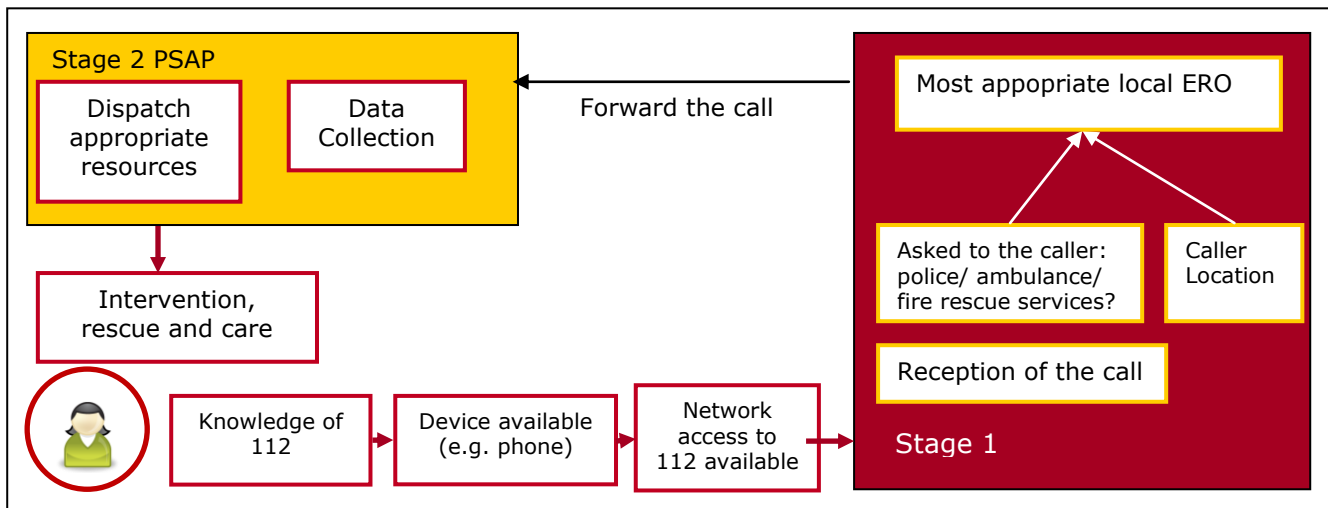

e.g. UK, Ireland, Netherlands

5.1.3 Data gathering and parallel dispatch by stage 1 PSAP, resource dispatching by stage 2

General description



As in the previous model, the handling of emergency calls is organised in two levels. The difference between the "Filtering Stage 1 PSAP and resource dispatching stage 2 PSAP(s)" and this model is the role played by the independent organisation. In this case, the 112 operator is in charge of the classification of the call and makes a parallel dispatch to the most appropriate EROs. In some cases police, fire and rescue and medical specialists are available to support the call takers.

112 calls handling chain in this model

112 calls handled by an ERO independent PSAP:

1. Classification and data gathering done by the stage 1 PSAP call taker: the operator asks what is happening and decides which EROs should be contacted depending on the information given by the caller. The operator gathers detailed data about the location and emergency situation of the caller.
2. Parallel dispatch to medical emergency / fire and rescue / police services if needed
3. Dispatch of the intervention resources done by emergency response organisation

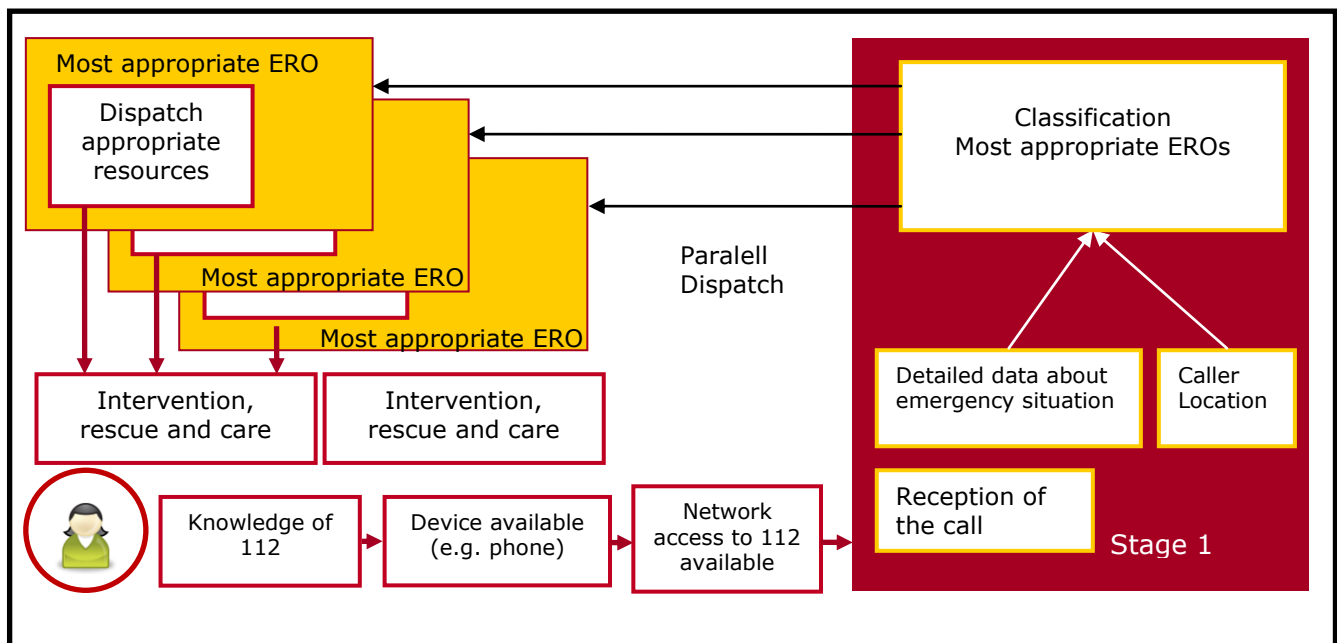

Variations to this model

- PSAPs of different regions can be interconnected. In this way, if there is no free operator available, the call can be redirected to another centre.

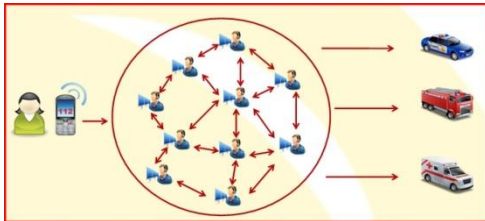

e.g. Bulgaria

5.1.4 Data gathering and parallel dispatch by stage 1 PSAP, resource dispatching by stage 2 in an integrated control room

General description

As in the previous model, the handling of emergency calls is organised in two levels. The difference between these two models is that emergency response organisations and 112 call-takers are in the same location. Sharing a physical space contributes to the improvement of the coordination between emergency services. In this case, the 112 operator is in charge of the classification of the call and makes a parallel dispatch to the most appropriate EROs. In some cases police, fire and rescue and medical specialists are available to support the call takers.

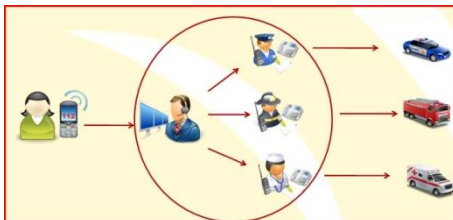

e.g. Region of Madrid, regions in Belgium

112 calls handling chain in this model

112 calls handled by an ERO independent PSAP:

1. Classification and data gathering done by the stage 1 PSAP call taker: the operator asks what is happening and decides which EROs should be contacted depending on the information provided by the caller. The operator gathers detailed data about the location and the emergency situation of the caller.
2. Parallel dispatch to medical emergency / fire and rescue / police services if needed
3. Dispatch of the intervention resources done by emergency response organisation

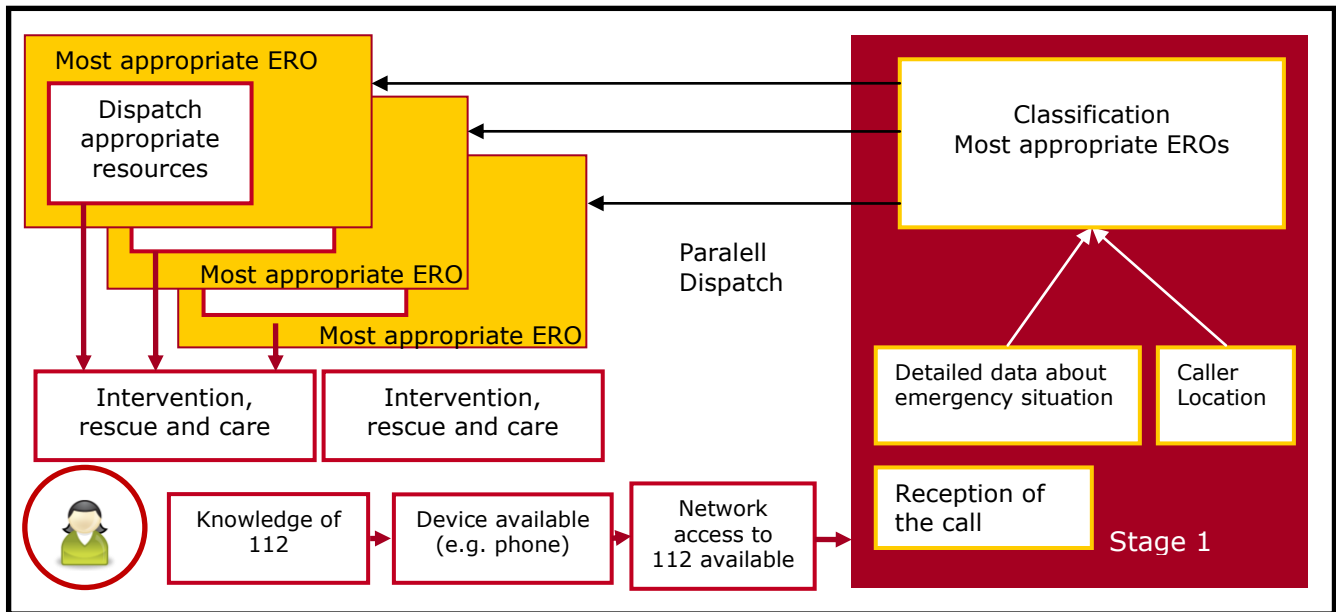

5.2 Emergency response organisation handling 112 calls

General description

112 calls are redirected to the emergency response organisations, e.g. police, fire and rescue or medical emergency services. If the intervention of a different emergency response organisation is required, the call and/or data about the emergency situation are forwarded to the most appropriate ERO.

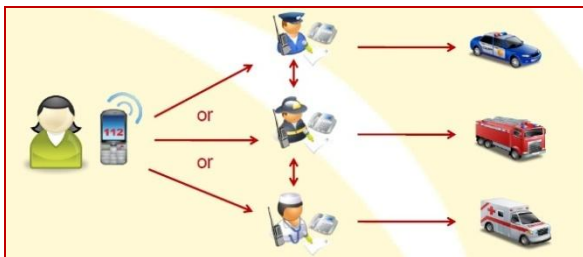

112 calls handling chain in this model

112 calls handled by PSAP operated by one emergency response organisation:

1. Reception of the call by a PSAP operated by an emergency response organisation
2. Dispatch to other emergency services (e.g. the 112 call is answered by the police but the citizen needs an ambulance): Call forwarded by the operator
3. Dispatch of the intervention resources done by the ERO operators

112 calls handling chain in this model

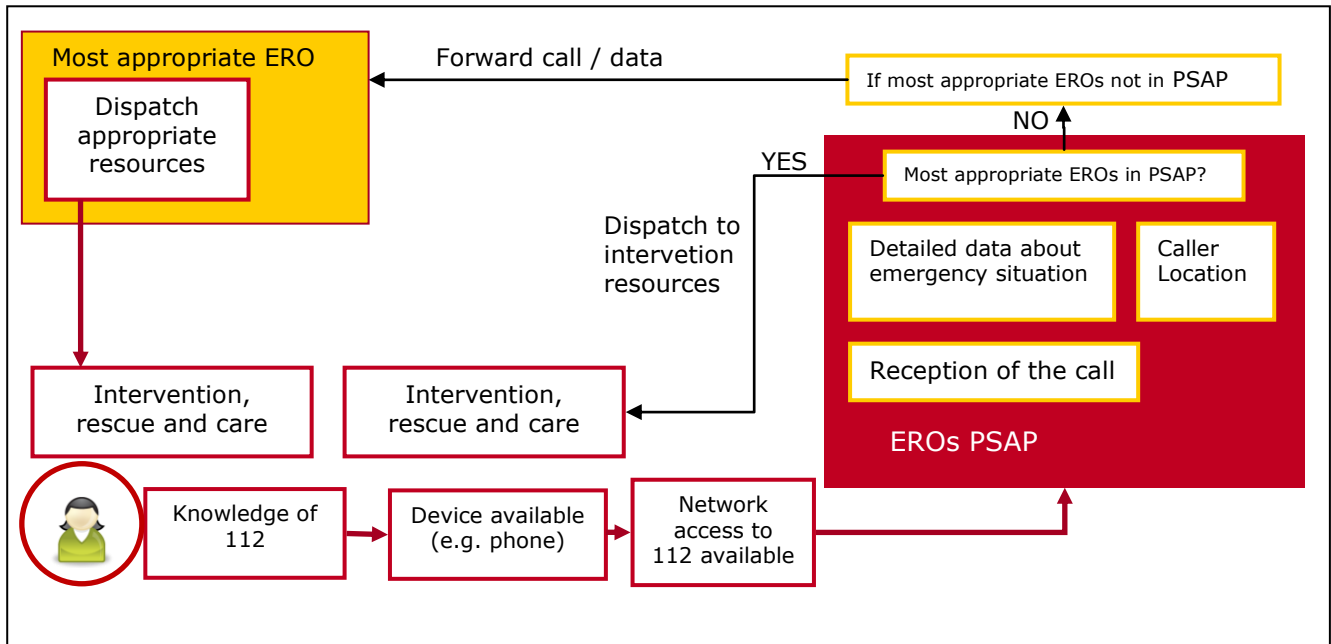

Variant of this model

- More than one emergency response organisations can be in the same location. Sharing a physical space contributes to the improvement of the coordination between emergency services.



ANNEX Organisation in different countries

This annex is provided for information purposes only. This annex only contains descriptions about 112 emergency number organisations. Descriptions of organisations dealing with other national emergency numbers are not included. The annex contains contributions submitted by our members as well as presentations of 112 national or regional systems made in the framework of the EENA Operations Committee. In some countries Organisational 112 models are being restructured. Consequently, discrepancies, inaccuracies or changes might occur when reading this annex.

Andorra

- 112 calls are managed by fire and rescue services

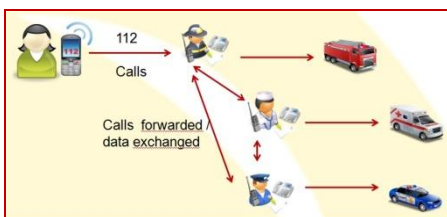

Austria

- Non-Police Calls are forwarded to the operationally and geographically responsible organisation (forward and/or conference call)
- Police and non-police PSAP's are organisationally and geographically separated



Belgium

- Depending on the region, the organisational model may be different.

Gent and Leuven Region
(in future for all regions)

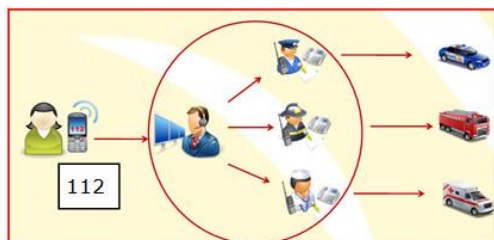

Rest of regions
(Present situation)

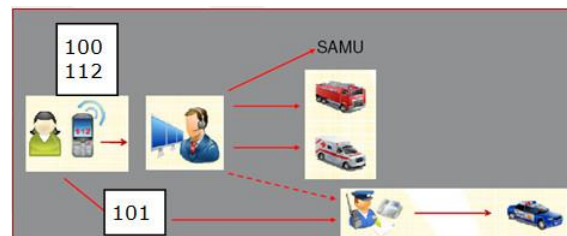

Bulgaria

- The system is 100% homogeneous across the country. Any centre can accept calls from any geographical point of the country (including geographical areas outside the corresponding region)

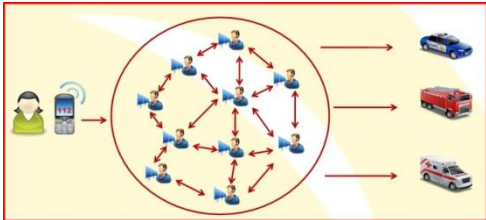

Cyprus

- 112 calls are received by the police

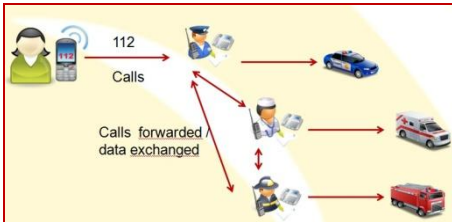

Croatia

- 112 calls are handled by ERO independent PSAP operators



Czech Republic

- 112 calls are managed by fire and rescue services
- All the PSAPs are interconnected

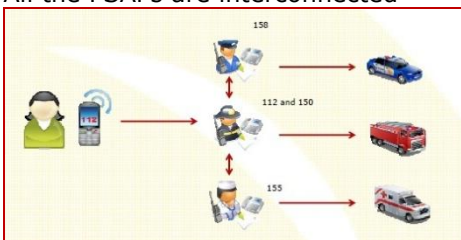

Denmark

- In some parts of the country police handles 112 calls and in others 112 calls are received by fire and rescue services

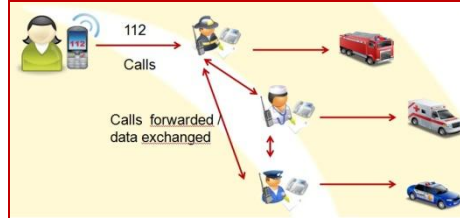

Estonia

- Fire and medical emergency services receive 112 calls and call handlers are integrated in the same coordination centres.



Finland

- The civilian 112 call-taker documents the answers to the questions about who, where, when, what, in order to evaluate the risk of the situation. The operator then decides the sort of the task and alerts the emergency service units if needed.



France

- 112 calls are handled by the fire and rescue services or by the medical emergency services local PSAP.

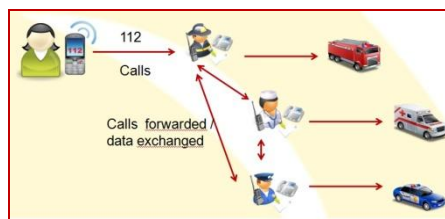
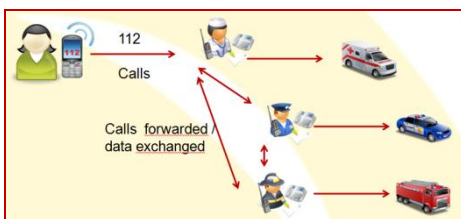

Germany

- 112 calls are handled by the fire and rescue services.

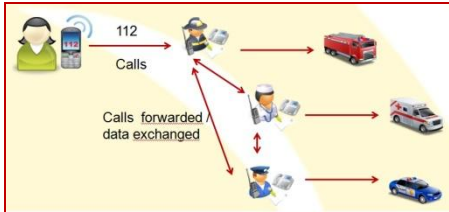

Greece

- Stage 1 PSAP operators receive the 112 calls and forward the call to the local emergency service organisation.

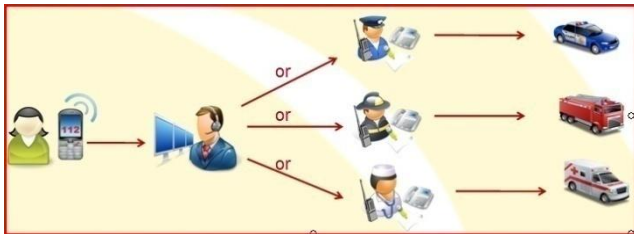

Hungary

- Currently 112 calls are taken by the county police depending on the location.
- In the future there will be 2 national PSAPs that will receive the calls and, if necessary, send the emergency data to the county emergency services organisations.

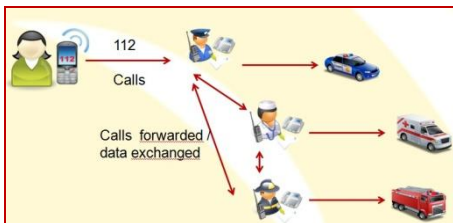

Ireland

- Stage 1 PSAP operators receive the 112 calls and forward the call to the local emergency service organisation.

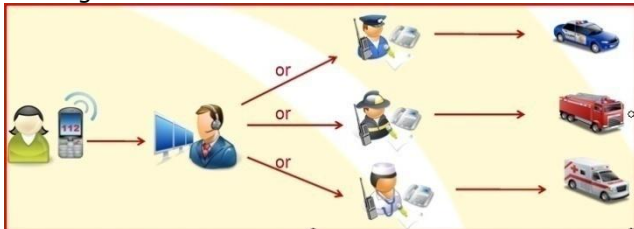

Italy

- Depending on the region, the organisational model may be different.

Lombardy region



Other regions

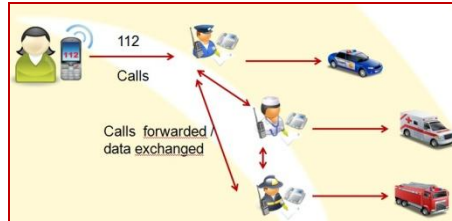

Latvia

- 112 calls are handled by the fire and rescue services

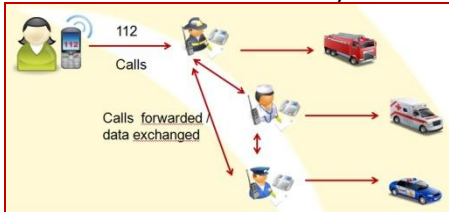

Lithuania

- Depending on the region, the organisational model may be different.

Vilnius



Other regions

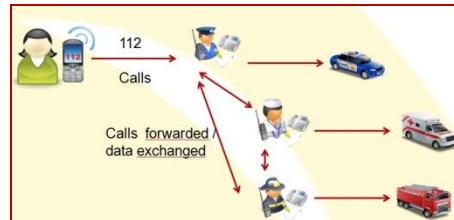

Luxembourg

- 112 calls are received in the control centre where medical, rescue and fire interventions are coordinated.

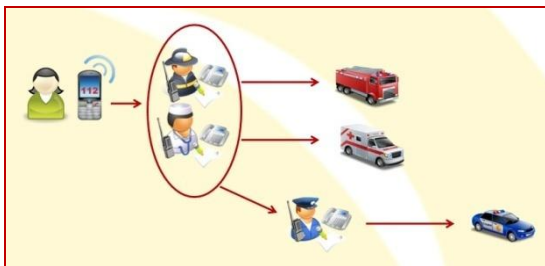

Malta

- 112 calls are handled by the police PSAP.

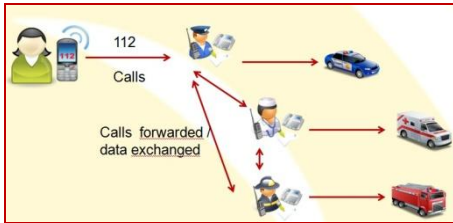

Netherlands

112 is organised as a multi-domain process and technique.



Norway

- 112 calls are received by the police.

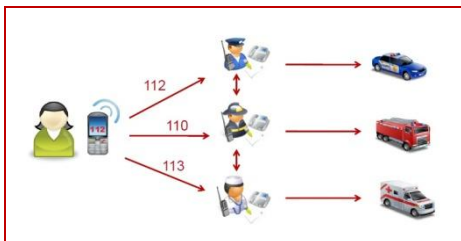

Poland

- Present situation

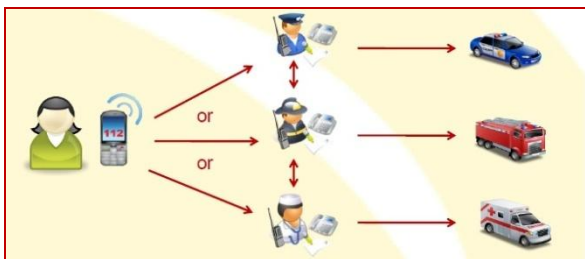

- Future situation

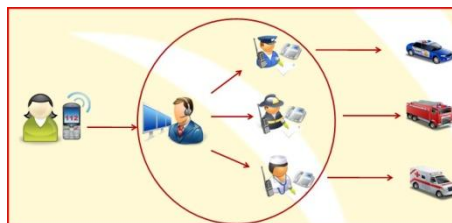

Portugal

- The call taking is done by one 1st line PSAP (Public Safety Answering Point)

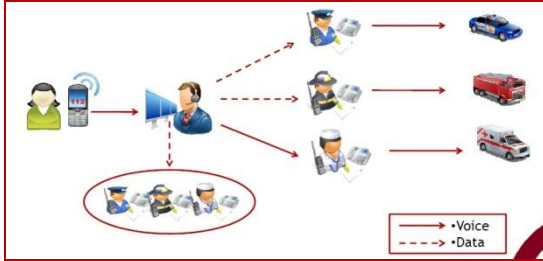

Romania

- 112 calls are answered by 112 call-takers, then they are processed and forwarded to the proper emergency intervention agencies



Serbia

- Present situation



- Future situation



Slovakia

- 112 calls are answered by 112 call-takers, processed and forwarded to the proper emergency intervention agencies



Slovenia

- Call filtered through PSAP and in case of Medical help needed transferred to regional emergency service



Spain

- Depending on the region, the organisational model may be different.

Region of Castilla La Mancha
Region of Madrid, etc.



Catalonia

Two operational interconnected 112 PSAPs. Fire and Police Department regional numbers redirected to the 112 PSAP.

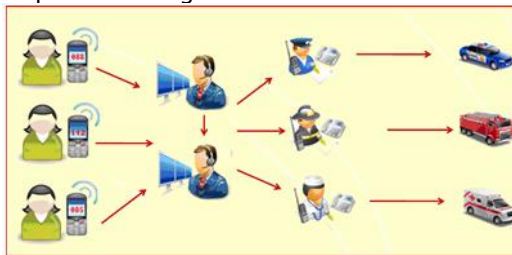

Region of Aragon
Region of Galicia, etc.



Sweden

- The 112 call-taker takes the data about who, where, when, what in order to evaluate the risk of the situation. The operator then decides the sort of the task and alerts the emergency service units if needed.



Turkey

- Depending on the region, the organisational model may be different.

Antalaya region:

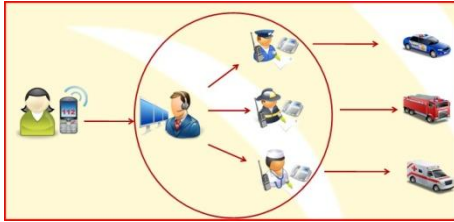

United Kingdom

- Stage 1 PSAP operators receive the 112 calls and forward the call to the local emergency service organisation.

